

Handy submersible drainage pump

IHP[®]

We pump water, sewage & slurry

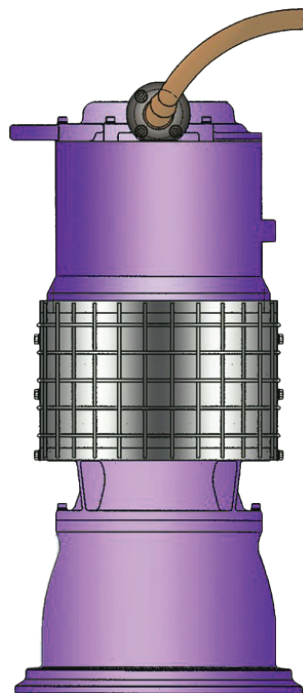

INDRA HYDRO TECH PUMPS PVT LTD

No.85/M, Ground Floor, Industrial Suburb, 2nd Stage Gautham Nagar, Tumkur Road Yeshwanthpur, Bangalore 560 022, Karnataka, INDIA
Tel. :+9180 4163 5638, Mobile:+9194835 26899 / 80736 22800, Email : sales@ihpumps.in, Web : www.ihpindia.in | www.ihpumps.in

Series presentation

MATERIALS			
Shaft	Stainless Steel	Oil Seal & O-Ring	Nitrile Rubber
Impeller	Stainless Steel	Bearing	Heavy Duty
Suction Casing	Aluminium	Mechanical Seal	Silicon Carbide
Motor Casing	Aluminium	Leakage Sensor	Float Switch
Pump Casing	Aluminium	Thermal Sensor	Bi-Metal
Discharge Casing	Aluminium	Bolts & Nuts	Stainless Steel
Strainer	Stainless Steel		

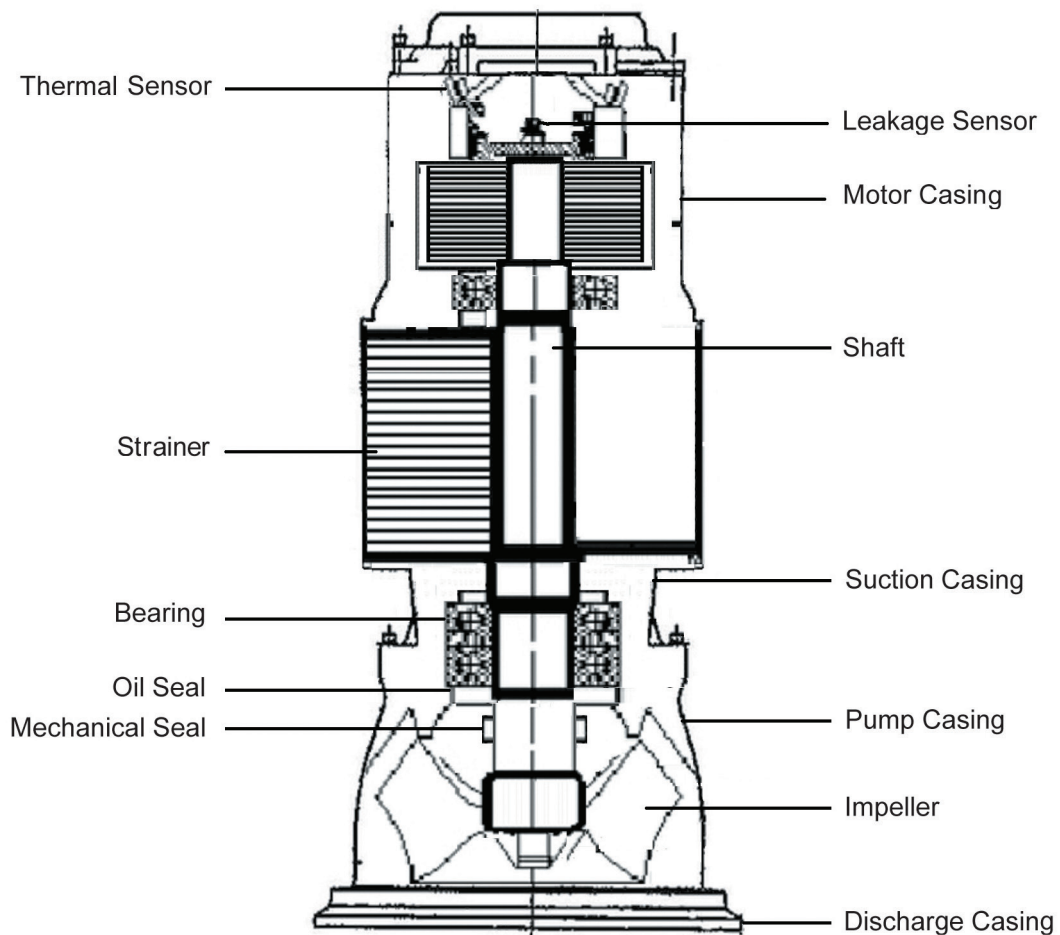

INDRA HYDRO TECH PUMPS PVT LTD

Performances

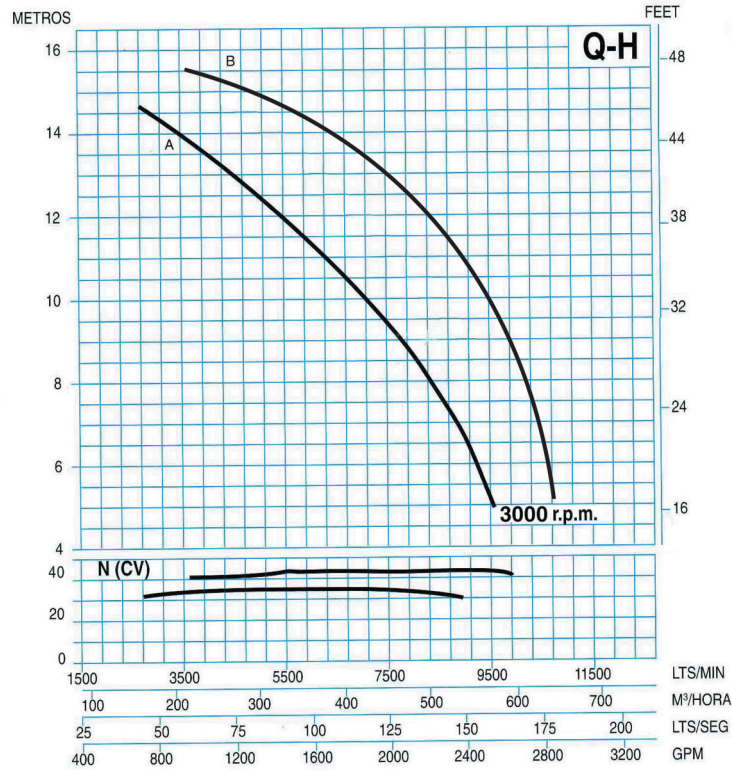

Overall dimensions

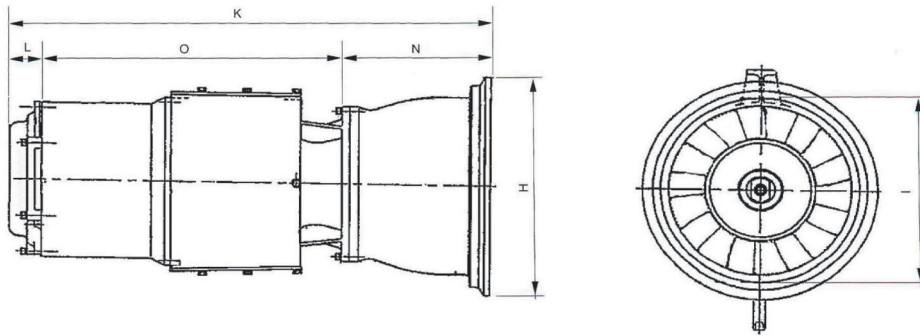

Dimension

TYPE	H	I	K	L	N	O	Kg
HDA200A/E-30T3	240	200	525	45	180	300	32

Technical Data

TYPE	RPM	KW	CV	AMP		IMP mm	PASO mm
				220	380		
HDA200A/E-30T3	3000	30	40	106	61	190	80

DESIGN CONDITIONS

ITEM NO.	1
QUANTITY	1
AIR TEMPERATURE °C	45
WATER TEMPERATURE °C	40
S.G.	1,0
VISCOSITY	1 cP
SUCTION CONDITIONS	Assume Flooded
FLOW RATE	500 m ³ /h
TOTAL HEAD	12.0 m

PUMP SELECTION

MODEL	HDA200A/E-30T3
TYPE	Handy Submersible Pump
INSTALLATION	Outdoor/Float
IMPELLER TYPE	Mixed Flow (One)
SPEED - RPM	3000
PUMP EFFICIENCY %	83.3
OVER ALL EFFICIENCY %	74.2
NPSH REQUIRED-M	5,00

PUMP CONSTRUCTION

SUCTION CASING	AC4C
IMPELLER	SCS 13
SHAFT	SUS304
DOUBLE MECHANICAL SEAL	Silicon Carbide
MOTOR FRAME	A5056
DISCHARGE CASING	AC4C
BEARINGS	Ball (Heavy Duty)
BOLTS AND NUTS	Stainless Steel

SENSOR

LEAKAGE SENSOR	1
MOISTURE SENSOR	1
THERMAL SENSOR	3

DRIVER (MOTOR)

TYPE	Air Filled Watertight Synchronous Motor (Cooling) Direct Type
RATING-KW	30
SPEED-RPM	3000
INSULATION CLASS	F
PROTECTION RATING	IP68
SERVICE FACTOR %	15
EFFICIENCY %	89.08
POWER FACTOR %	75
STARTING METHOD	Inverter
VOLTS/PHASE/HZ	380/3/50
CABLE M.	100

SPARE PART

MECHANICAL SEAL	-
UPPER & LOWER BEARING	-
MAIN & CONTROL CABLE	-
O-RING	-
OIL SEAL	-
THERMAL SENSOR	-
IMPELLER	-
WEARING RING	-

IHP[®]

We pump water, sewage & slurry

INDRA HYDRO TECH PUMPS PVT LTD

No.85/M, Ground Floor, Industrial Suburb, 2nd Stage Gautham Nagar, Tumkur Road Yeshwanthpur, Bangalore 560 022, Karnataka, INDIA
Tel. :+9180 4163 5638, Mobile:+9194835 26899 / 80736 22800, Email : sales@ihpumps.in, Web : www.ihpindia.in | www.ihpumps.in